



### FOR SALE

## Situated in the Highly-Desirable Johnson County Submarket



### Prestigious Mixed-Use Business Park

- 46,045 RSF Office Building For Sale in Johnson County
- Single Occupant Office Building with Dock-High Access
- Excellent access and location in the highly-desirable Johnson County submarket
- 15 minutes from downtown Kansas City and less than 30 minutes from the Kansas City International Airport
- Ample parking which is designed with spaces close to building entrances

### For more information:

Kenneth G. Block, SIOR, CCIM  
816.932.5551  
kblock@blockllc.com

Andrew T. Block  
816.412.5873  
ablock@blockllc.com

Hagen Vogel  
816.878.6338  
hvogel@blockllc.com

The information contained in this marketing flyer is presented as general information only. Block Real Estate Services, LLC. makes no representation as to its accuracy. This information is not intended as legal, financial or real estate advice and must not be relied upon as such. You should make your own inquiries, obtain independent inspections, and seek professional advice tailored to your specific circumstances before making any legal, financial or real estate decisions.



### General Building Information

<b>Location:</b>	10310 W. 84th Terr., Lenexa, Kansas
<b>Building Size:</b>	46,045 RSF
<b>Land Area:</b>	4.37± acres; 190,221± SF
<b>Parking Ratio:</b>	117 Surface Spaces 4 / 1,000 Square Feet
<b>Year Constructed:</b>	1984, Expanded in 1987 and 1989
<b>Building Construction:</b>	Steel structure, brick and glass exterior walls, tar and gravel roof.
<b>Zoning:</b>	BP-1
<b>Sprinkler:</b>	Yes
<b>Sale Price:</b>	\$7,090,930 (\$154 PSF)
<b>Utilities (Lessee):</b>	Electricity - Kansas City Power and Light Gas - KPL Gas Services Water - Water District #1 of Johnson County
<b>CAM:</b>	\$9.03

#### For more information:

Kenneth G. Block, SIOR, CCIM  
816.932.5551  
kblock@blockllc.com

Andrew T. Block  
816.412.5873  
ablock@blockllc.com

Hagen Vogel  
816.878.6338  
hvogel@blockllc.com

# 8 Pine Ridge Plaza

10310 West 84th Terrace, Lenexa, Kansas



## Pine Ridge Business Park

### 1st & 2nd - Floor Plan

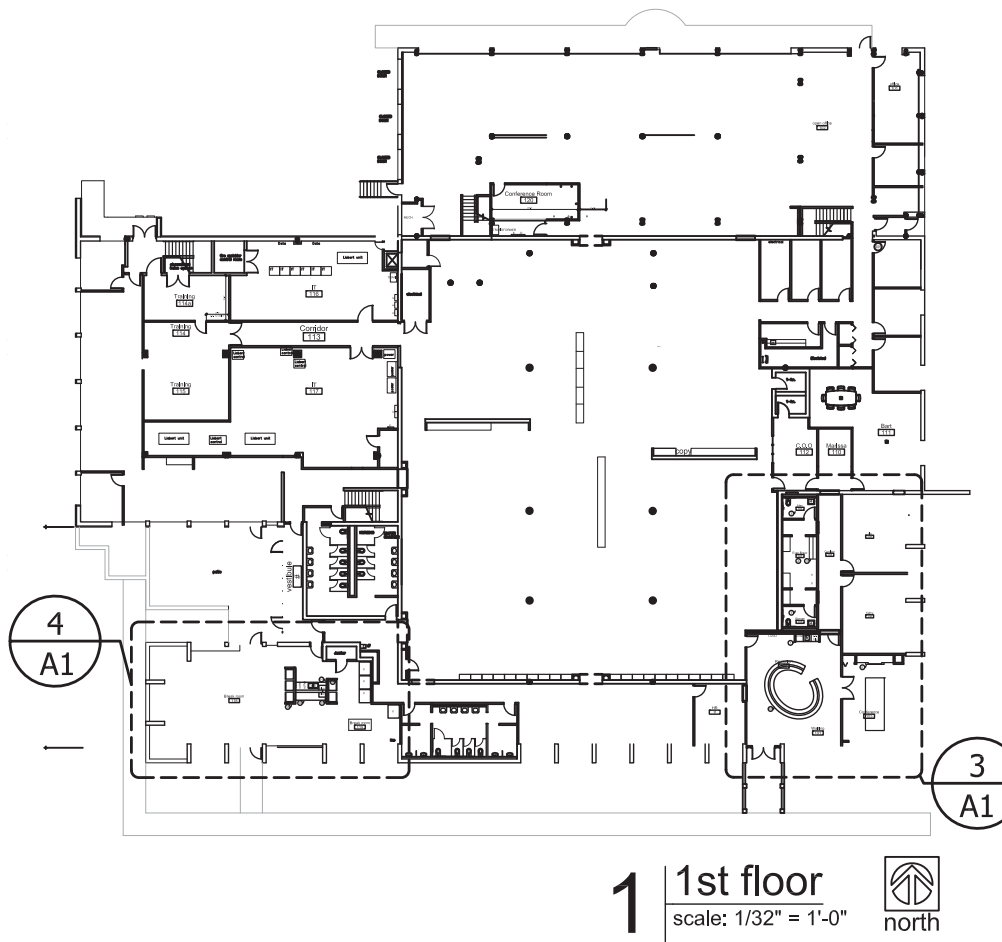
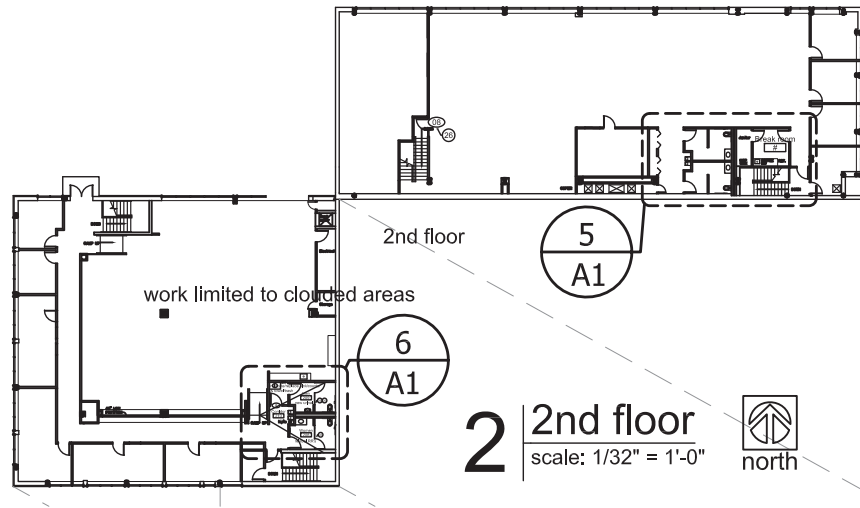

# 8 Pine Ridge Plaza

10310 West 84th Terrace, Lenexa, Kansas

Site Plan

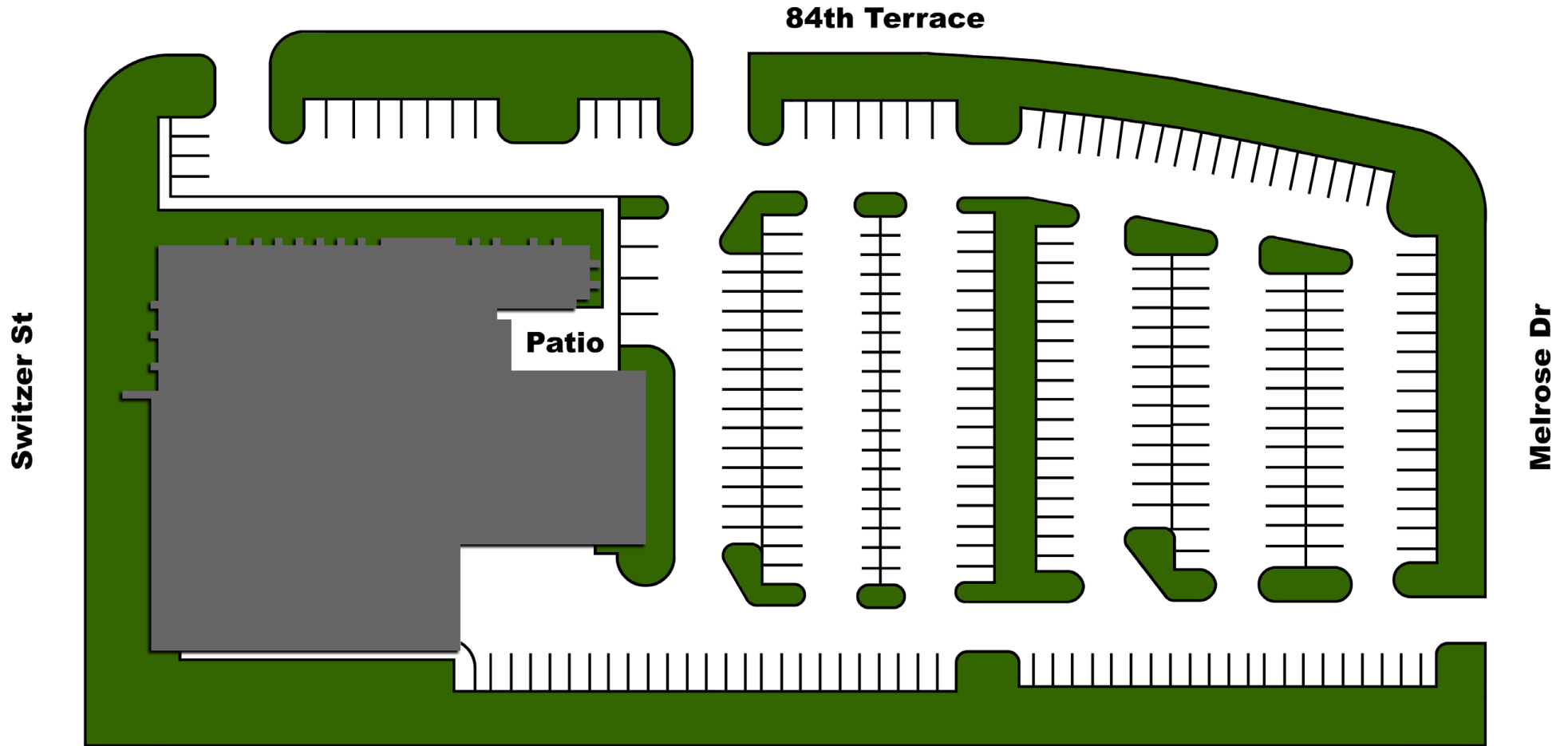

# 8 Pine Ridge Plaza

10310 West 84th Terrace, Lenexa, Kansas



## Pine Ridge Business Park

### Business Park Map



# 8 Pine Ridge Plaza

10310 West 84th Terrace, Lenexa, Kansas



Aerial Map

